

POWERFLEX®

PART NUMBER

PFF32-901

DESCRIPTION

FRONT RADIUS ARM TO CHASSIS BUSH

INSTALLATION GUIDE

Contents (parts per pack):

- | | |
|------------------------------------|-----------------------------|
| 2 x Polyurethane Bushes | 2 x Stainless Steel Sleeves |
| 4 x Zinc Plated Mild Steel Washers | 1 x PTFE/Silicone Grease |
| 2 x Zinc Plated Mild Steel Shells | |

Please read the complete fitting instructions and check package components before fitment. These fitting instructions are to be used as a guide and in conjunction with workshop manual.

It is recommended that:

- all work to be carried out by a licensed technician;
- all safety precautions adhered to;
- wheel alignment to be checked and adjusted as required after any suspension work.
- All fasteners must be torqued to the manufacturer's specified settings.

Fitting Instructions:

1. Remove the original bush and its outer shell from the arm.
2. Clean any dirt or burrs from the bore in the arm. Remove any sharp edges with a rounded file.
3. Press the plated outer shell into the arm, until sitting flush to the face of the arm.
4. Apply some washing up liquid to the bore of the shell and press the polyurethane bush in until fully through the arm.

Tip: If you are having trouble pressing the bush in, try pressing the bush in at a slight angle so that one part of the lip is already in the bore of the shell; when steady pressure is applied, the rest of the lip should follow.

5. Apply some of the provided grease to the bore of the bushes and fit the Stainless Steel sleeve into the bushes.
6. Apply grease to the mounting faces of the bush that come into contact with the washers.
7. Ensure that the washers are fitted and correctly seated on the outside face of each bush prior to final torquing of any fixings.
8. Torque all hardware to manufacturers recommended torque settings.

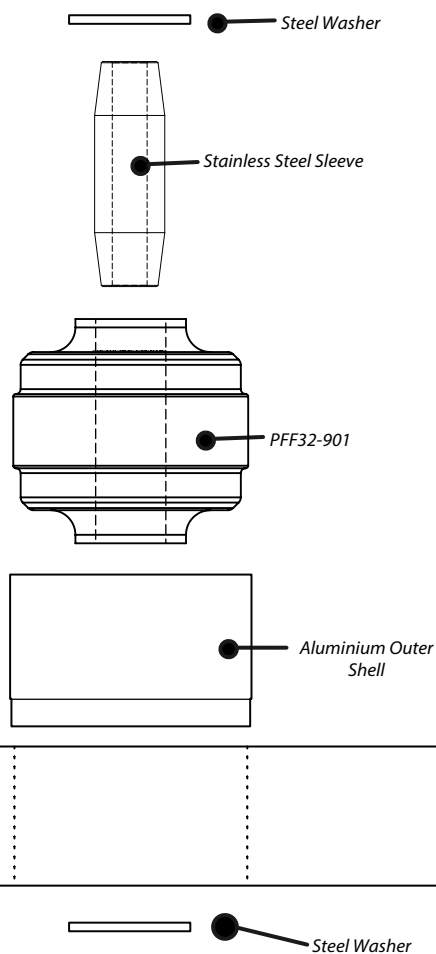

Figure 1